

ENG. NO. 72999-G
 PAT. NO. 5,203,496.
 5,323,960.
 6,637,668.
 7,140,394.

Thermostatic Water Controller Model 801 High-Low Water Mixer Unit No. 72999

 ASSE 1017 Approved



Certified to
 CSA B125.3

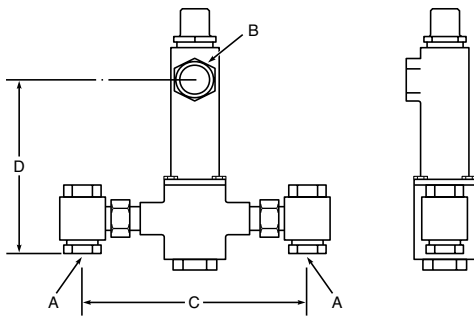

Master water mixing valve shall be of the thermostatic type with liquid-filled thermal motor. It shall have bronze body construction with replaceable corrosion-resistant components. Valve construction shall employ a sliding piston control mechanism. Sliding piston and liner shall be of stainless steel material. Valve shall come equipped with union end stop and check inlets with removable stainless steel strainers. Valve shall control temperature from a low flow of 1 GPM* up to a maximum flow rate for a given pressure differential. Valve shall provide protection against hot or cold supply line failure and thermostat failure.

DIMENSIONS:

Valve Number	A N.P.T.	B N.P.T.	C	D
801	3/4"	1"	10"	12"

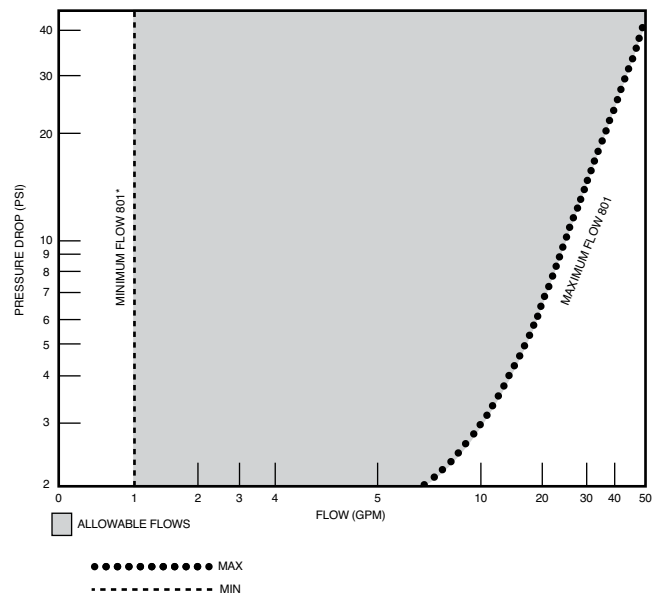

FINISH: Bronze
 Chrome
 Other

TEMP. RANGE **SET POINT**

70° to 100°F 80°F
 90° to 120°F 110°F
 110° to 140°F 130°F
 Special _____

Optional Test Connection
 Including garden hose connection, shut-off and thermometer.

Bronze
 Chrome

CAPACITIES - MODEL 801

Pressure Drop PSI	5	10	20	30	45	60	80
Valve Number	Capacity						
801-GPM	17	25	34	40	50	57	65
801-LPM	64	94	128	151	189	210	246

*1/2 gpm when properly installed in recirculated system.



MANUFACTURING CO., INC.

5330 East 25th Street
 Indianapolis, Indiana 46218
 Phone (317) 261-1212
 Fax (317) 261-1208

Design and specification subject to change without notice.