

LAWLER

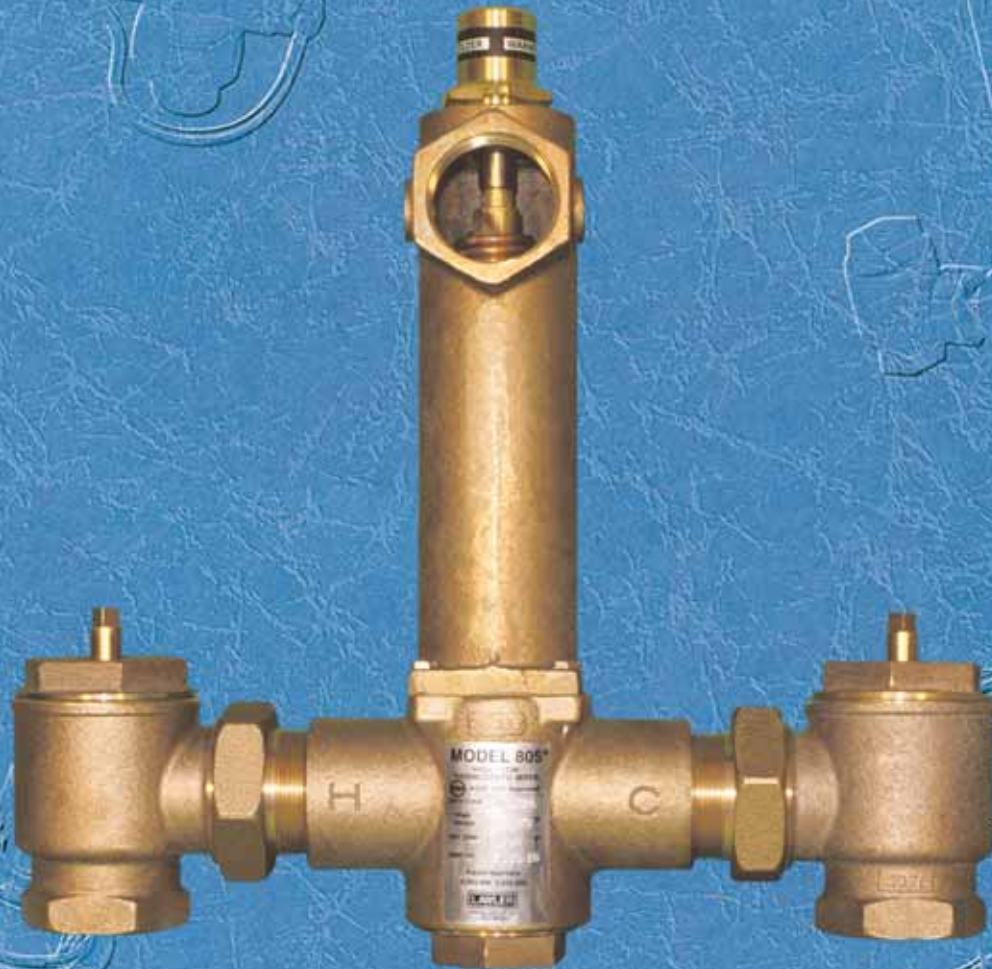

MODEL 805[®] (PAT NO. 5,203,496)
(PAT NO. 5,323,960)

HIGH-LOW WATER MIXER

WHEN TEMPERED WATER
IS REQUIRED OVER A WIDE RANGE OF FLOWS

Minimum Flow 5 GPM*

Rated Flow 200 GPM

(*1/2 GPM when properly installed in recirculated system)



ASSE 1017 Approved.



Certified to CSA B125.3

LAWLER MANUFACTURING CO. INC., Indianapolis, IN

LAWLER MODEL 805[®]

Wide Flow Range Thermostatic Mixer

The Solution To Oversizing Problems

Many institutional, commercial and industrial applications face the challenge of delivering tempered water over a wide range of flows. Most valves cannot handle the complete range of flows. In many cases multiple valves have to be used to satisfy flow requirements.

Lawler's Model 805 solves this problem.

The wide range of flows will eliminate the need for expensive multi-valve systems in most applications.

Lawler was able to achieve wide flow range performance by drawing on previous design experience with low flow valves.

The 805 is able to accurately control both high and low flows because it has been designed to eliminate the problems experienced at low flow ranges in other valves.

- Directed Flow—water flow is forced over the thermostat and cannot short circuit
- Mixing Chamber—Lawler's exclusive mixing chamber expands, contracts and rotates the flow so that it is completely mixed prior to flowing over the thermostat.
- Multiple Inlet Ports—rapid mixing is initiated by multiple inlet ports.

Three-Way Protection

1. Thermostat Protection.

Lawler's exclusive design cuts water flow if the thermostat's liquid motor fails.

2. Hot Supply Protection.

Responds automatically if the hot water supply is interrupted, or if the temperature changes.

3. Cold Supply Protection.

Guards against scalding if the cold water supply is interrupted.

Lawler Thermostatic Valves adjust for changes in both input temperature and pressure, maintaining constant output.

When safety is important, specify Lawler.

*1/2 gpm when properly installed in recirculated system.

APPLICATIONS

- Nursing Homes
- Hospitals
- Hotels
- Schools
- Prisons
- Not to be used in Emergency Shower Applications

Max. Inlet Conditions

Pressure: 125 psi
Temperature: 200°F

Recommended Conditions

Minimum Flow

5 Gallons Per Minute (gpm)*

Minimum Temperature Differential

Hot and cold water inlets must have a minimum 20°F differential from the outlet set temperature.

Performance

The Model 805 will maintain outlet temperature under any of the following conditions, providing the recommended minimum flow and minimum supply temperature differentials are not exceeded:

- reduction to 5 gpm*
- 30°F change in hot water temperature
- 30°F change in cold water temperature
- 50% drop in inlet supply pressure

TEMP. RANGE	SET POINT	
70° to 100°F	80°F	<input type="checkbox"/>
90° to 120°F	110°F	<input type="checkbox"/>
110° to 140°F	130°F	<input type="checkbox"/>
Special _____	_____	<input type="checkbox"/>

FINISH

- Rough Brass
- Polished Chrome
- White Chrome
- Special
- PTFE Coating
- Nickel Coating

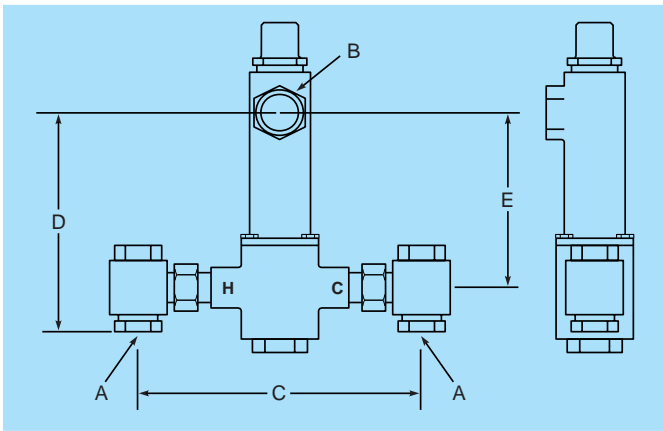

DIMENSIONS:

Valve Number	A N.P.T.	B N.P.T.	C	D	E
805	2"	2"	15"	13"	11"

CAPACITIES - MODEL 805

Pressure Drop PSI	5	10	20	30	45	60	80
Valve Number	Capacity						
805-GPM	64	96	133	165	200	230	265
805-LPM	242	363	503	624	757	870	1003

ELIMINATES SELECTION CONCERNS

Lawler's Model 805 simplifies your choice to one valve which is the proper selection over an extremely wide flow range.

The 805 is sized correctly for any pressure drop/flow condition which falls in the shaded area of the graph to the right.

Higher maximum flows may be achieved by installing two 805 valves in parallel. Such an installation will double the maximum and minimum flows.

TYPICAL SPECIFICATION

Master water mixing valve shall be of the thermostatic type with liquid filled thermal motor. It shall have bronze body construction with replaceable corrosion resistant components. Valve construction shall employ a sliding piston control mechanism. Sliding piston and liner shall be of stainless steel material. Valve shall come equipped with union end stop and check inlets with removable stainless steel strainers. Valve shall control temperature from a low flow of 5 gpm* up to a maximum flow rate for a given pressure differential. Valve shall provide protection against hot or cold supply line failure and thermostat failure.

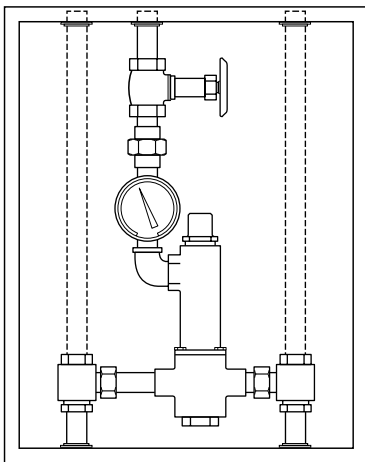
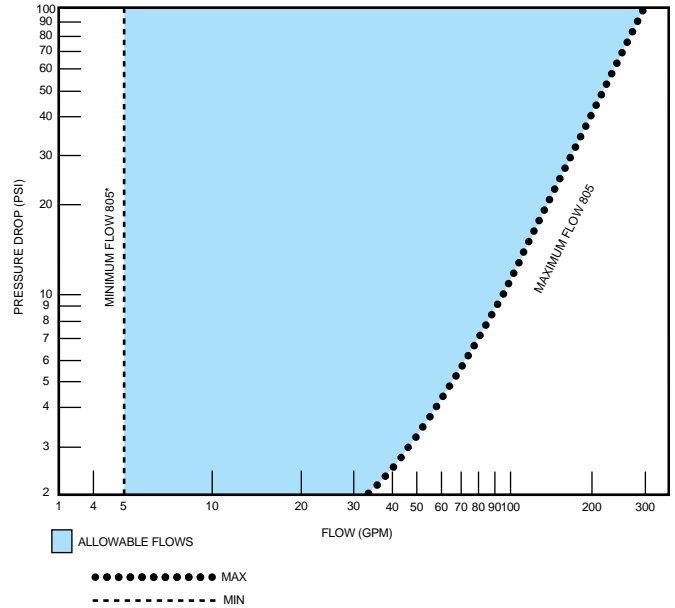

MODEL 805 FEATURES

- Easy to install—can be completely repaired without being removed from the system.
- Compensates for supply line temperature and pressure changes.
- Outlet flow is greatly reduced upon supply line or thermostat failure.
- Inlets are fully rotatable through 360° and outlet is rotatable through 360° in 90° increments—full flexibility is provided for roughing in the valve.
- Tamper-resistant control adjustment.
- Rugged design equipped with stainless steel piston and liner.
- Requires smaller installation space than manifolded systems.

*1/2 gpm when properly installed in recirculated system.

Typical Installation

Install the mixing valve below the hot water tank or heater. If this is not possible, pipe in a heat trap as shown in Figure 1 with an approximate 2' drop.

Connect a tempered water return line as shown in Figure 1. This allows flow through both ports of the mixing valve during periods of no draw.

If a dual temperature system is used, a separate recirculating loop and pump are required to return high temperature hot water to the water heater. See Figure 2.

Install an aquastat at the tempered water return pump.
Install the water heater per manufacturer's instructions.

Setting The Mixing Valve To The System

1. After installations be sure to flush the system thoroughly.
2. Make sure the hot water supply is heated to normal design temperature.
3. Close and tag all fixtures to ensure they are not used during this procedure.
4. Turn off the recirculating pump.
5. Create a draw on the system greater than the minimum flow rating of the mixing valve. All open fixtures must be tagged to ensure they are not tampered with or used during this procedure.
6. Allow water to flow through the mixing valve until the water temperature is stable. If necessary, re-adjust the mixing valve in accordance with the TEMPERATURE ADJUSTMENT section of the installation manual.
7. Once the temperature is set, start the recirculating pump and allow the system to reach set temperature.
8. Measure the water temperature at the return pump and adjust the aquastat to shut off the pump should the return water exceed the set point by 2°F. Set the low limit switch to restart the return pump when return water drops 5°F below the set temperature.
9. Set the balancing valve in the full open position.
10. Shut off all fixtures and ensure there is no draw on the system. The cold inlet to the mixing valve should be warm.
11. Allow the system to run in this condition for at least 30 minutes.
12. In some cases, an increase in water temperature may occur during a no draw period. If this occurs, slowly close the balancing valve until the water temperature is back to the original set temperature.

Figure 1

Typical Installation

When used in a single temperature recirculating system

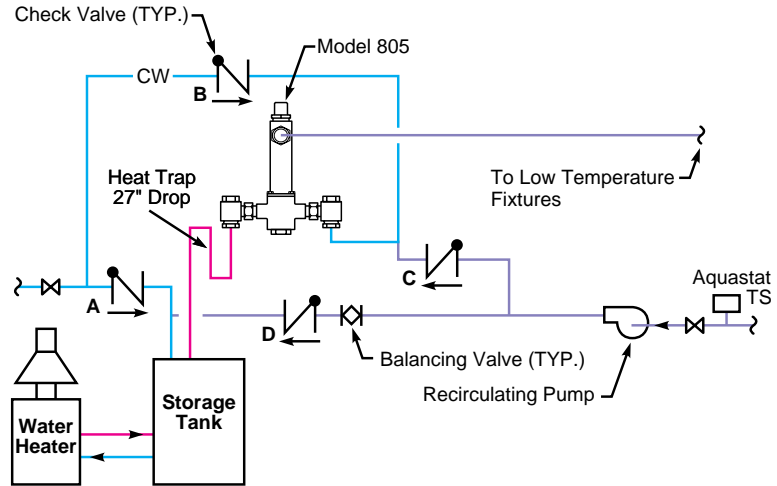
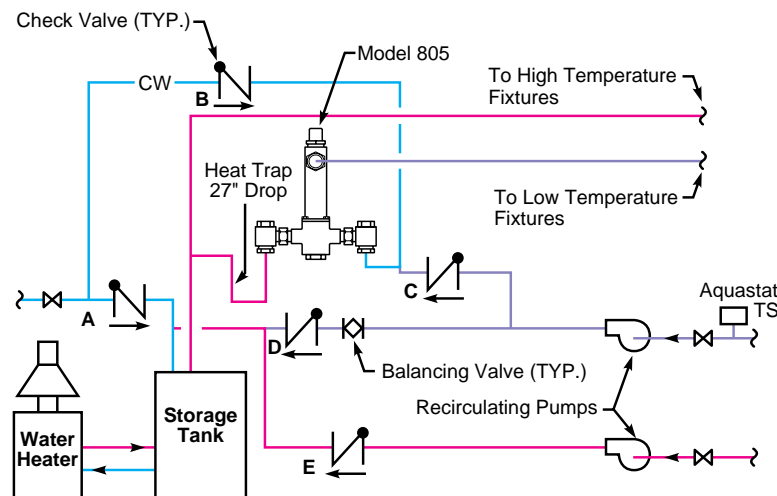

Figure 2

Typical Installation

When used in a dual temperature recirculating system



MANUFACTURING CO., INC.

5330 East 25th Street
Indianapolis, Indiana 46218
Phone (317) 261-1212
Fax (317) 261-1208

www.lawlervalve.com